



XL系列母线槽系统

XL Series Busbar Trunking System



www.jshongpeng.com

江苏宏鹏电气科技有限公司

JIANGSU HONGPENG ELECTRIC TECHNOLOGY CO.,LTD.

公司简介

江苏宏鹏电气科技有限公司专业从事电气产品研发、生产、销售的专业子公司。公司位于江苏省扬中市新坝镇，注册资本 10088 万元。是江苏省重点扶持的成长型企业、江苏省民营科技企业、国家高新技术企业、镇江园林式单位、镇江“重合同、守信用”企业、“AAA”级信用企业。

公司秉承“领先技术、卓越品质、专注服务”的核心价值观，凭借雄厚的实力和先进的管理，先后通过了 ISO9001 质量管理体系认证、ISO14001 环境管理体系认证和 OHSAS18001 职业健康安全管理体系认证，产品全部通过了国家强制性 3C 认证。

公司拥有专业的研发团队，同时引进进口加工设备和先进的制造工艺，努力打造系列化、多元化、高品质的产品。主要产品有高低压成套开关设备、高低压母线槽、智能电气设备、配网三相不平衡补偿装置、电缆桥架等。公司目前已在北京、上海、广州、深圳、天津、重庆、南京、武汉、西安、成都、济南、沈阳、长春、哈尔滨、兰州、杭州等地设立办事处，各驻外机构均配备具有丰富专业知识的工程师，为顾客提供贴近、便捷的服务。

“诚信立足，创新致远”，江苏宏鹏电气科技有限公司与您共创价值，服务民族产业！为打造中国电气行业著名企业而努力！



Jiangsu Hongpeng Electric Technology Co., Ltd, in Yangzhong city xinba zone Jiangsu Province, covers an area of 100,000 square meters with registered capital of 100.88 million Yuan. It is a developing company supported by People's government of Jiangsu Province. What's more, it bears the honor as Jiangsu Province Technology Enterprise, National High-tech Enterprise, Zhenjiang Garden-Style Unit, Zhenjiang "Contract-abiding & Trustworthy" Enterprise and AAA Grade Credit Enterprise.

The core value of the company is "advanced technology, excellent quality and dedicated service". With its strong capacity and advanced management techniques and technologies, Aimhigh has achieved the ISO9001 quality management system certificate, ISO14001 environmental management system certificate, OHSAS18001 occupational health and safety management certificate. Moreover, all the products have got the China Compulsory Certificate.

The company owns the professional development team, imported equipment and advanced manufacturing processes. It strives to manufacture serialized, diversified and high-quality products. The main products includes high and low voltage switchgears, high and low voltage busways, intelligent electrical equipment, Three phase unbalanced compensation device for distribution network etc. cable trays , We have set up office in Beijing, Shanghai, Guangzhou, Shenzhen, Tianjin, Chongqing, Nanjing, Wuhan, Xi'an, Chengdu, Ji'nan, Shenyang, Changchun, Harbin, Lanzhou, Hangzhou to provide close and convenient service for customers.

Based on the idea of "Faith and Innovation", Jiangsu Hongpeng Electric Technology Co., Ltd together with you is going to create value, serve for the national industry and strive to build a well-known Chinese electrical enterprise!

目 录 Contents

第一部分 XL系列密集型母线槽	1
•系统概述	1
•产品特点	3
•技术参数	6
•产品编号	8
•功能单元	10
•安装	15
第二部分 XL-N系列耐火母线槽	19
•系统概述	19
•技术参数	20
第三部分 XL-R系列低压浇注母线槽	21
•系统概述	21
•产品应用	22
•系统图	23
第四部分 XL-K系列空气绝缘母线槽	24
•系统概述	24
•技术参数	25
第五部分 XL-ZM系列微动力照明母线槽	26
•系统概述	26
•技术参数	27
第六部分 注意事项	28

【系统概述】 System overview



XL 系列密集型母线槽是江苏宏鹏电气科技有限公司充分吸收当今世界最先进母线技术的同时，经过数十年的潜心研发推出的一款新型母线槽。该产品符合GB7251和IEC60439标准，有铜排和铝排两种配置，额定工作电压690V，额定绝缘电压1000V，频率50~60Hz，额定工作电流250~5000A，分接电流最大1600A，防护等级有IP42、IP54，最高可达IP66。适用于三相三线制、三相四线制、三相五线制等供电系统。

XL 系列密集型母线槽具有结构新颖、外形美观、性能可靠、安装方便、经济实用等特点，技术水平居国际先进水平。可广泛应用于大型商业广场、高层建筑、智能化楼宇、体育馆、工业厂房、医院等重要场合，是综合性能最佳的输配电系统。

针对工矿企业对母线槽短时耐受、低阻抗等方面有很高的要求，以及可能存在的各类电磁干扰，XL 系列母线槽系统内可选的中性线（100%或200%），可满足各种电力系统对消除谐波的要求。全弱磁铝合金外壳，有效降低了涡流和磁滞损耗对母线槽系统造成的影响。

Fully absorbing the world's most advanced busway technology, Jiangsu Hongpeng Electric Technology Co., Ltd launched XL series compact busway, a new type busbar trunking system, after decades of painstaking research and development. This product, with copper or aluminium conductor, complies with GB7251 and IEC60439 standards, suitable for three-phase three-wire, three-phase four-wire, three-phase five-wire power supply and distribution, with rated operation voltage up to 690V, rated insulation voltage 1000V, rated current from 250A to 5000A, maximum tapping current 1600A, IP degree up to IP66 and the frequency 50~60Hz.

XL series compact Busway is equipped with novel structure, beautiful appearance, reliable performance, easy installation, economical and practical characteristics, presenting its international advanced technical merit. It is the transmission and distribution system with best combination property because it can be widely used in large commercial Plaza, high-rise buildings, intelligent buildings, stadiums, industrial plants, hospitals and other important occasions.

Concerning industrial and mining enterprises' high demand to busbar trunking's short time withstand and low impedance ability, as well as various types of electromagnetic interference that might exist, the optional neutral wire (100% or 200%) within the XL series Busbar system can meet the requirement for eliminating harmonics in a variety of power systems. Weak magnetic aluminum alloy shell effectively reduces the influence on busbar trunking system caused by eddy currents and hysteresis loss.

【系统概述】 System overview

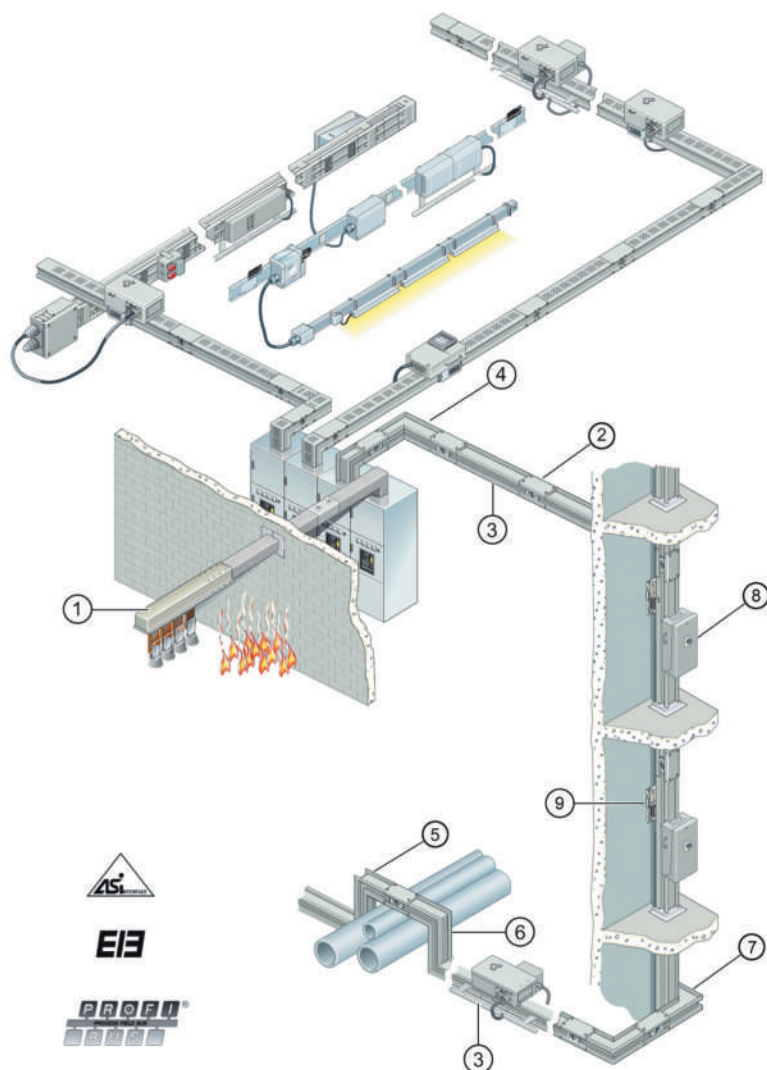

Figure 3-1 Overview of busbar trunking systems

- 1、变压器连接单元 Transformer Connection Unit
- 2、连接器 Joint
- 3、直线段母线 Straight Length Busway
- 4、水平弯头 Flatwise Elbow
- 5、垂直弯头 Edgewise Elbow
- 6、Z型垂直弯头 Z Type Edgewise Elbow
- 7、异型弯头 Nonstandard Elbow
- 8、插接箱 Plug-in Box
- 9、弹性支撑器 Spring Hanger

【产品特点】Product features

三明治导体结构

全长密集，不会形成“烟囱效应”。
 结构紧凑，占用的建筑物空间更小。
 导体紧密排列，整体散热，温升更低。
 插口处母排不打弯，高密度、低阻抗。
 防错相设计，确保安装时相序正确无误。
 载流能力不受安装位置及安装方式的影响。

Whole-length compact type, no chimney effect
 Sandwich structure, less space occupied
 Conductor tightly arranged, overall heat dissipation, slow temperature rising
 No busbar bending on outlet, high intensity, low impedance
 Phase-dislocation proof design, ensuring correct phase sequence during installation
 Current-carrying capacity is not affected by installation location and methods

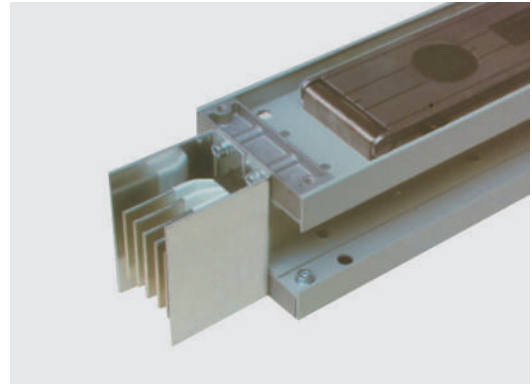

铝镁合金外壳 Al - Mg

Alloy Housing

XL 系列母线槽采用重量轻、一次挤压成型的铝合金型材作为外壳，具有较高的机械强度，能够从容应对各种特殊的应用条件。

全铝外壳具有优良的导电性能，整体外壳不低于100%相线的接地容量。

铝合金外壳为弱磁材料，能有效避免涡流和磁滞损耗对母线槽系统造成影响。

特有的锯齿散热片，极大地提高了母线系统的散热能力。

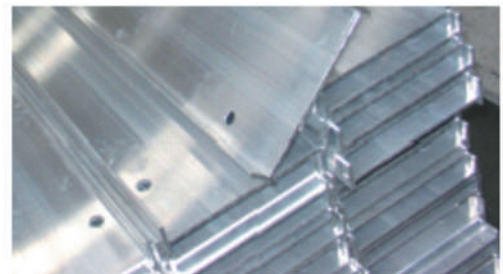

The light-weighted housing used by XL Busbar is aluminium alloy sectional bar formed by one-time extrusion, with high mechanical strength, being able to deal with a variety of special application conditions.

All aluminum housing has excellent conductive property, grounding capacity of the overall housing is no

less than that of 100%-phase line.

Al-alloy shell, weak magnetic material, can effectively avoid effect on busway system caused by eddy currents and hysteresis loss.

Unique jagged fins greatly improves the thermal capacity of busway system.

【产品特点】Product features

单螺栓连接器 Single-bolt

Joint

摒弃了传统的设计，采用了单螺栓夹紧机构，使得安装快捷、可靠，其安装速度较传统连接器快一倍。

采用了双头定扭矩螺栓，确保了连接所需的压力；配以特制的碟形弹簧，确保了连接接触面间的持久压力。

设有温度指示模块，确保在系统故障、温升过高时可以提醒检修。

连接母排截面是母线槽母排截面的1.2倍以上，同时接触面为双面搭接，有效降低了接触电阻。

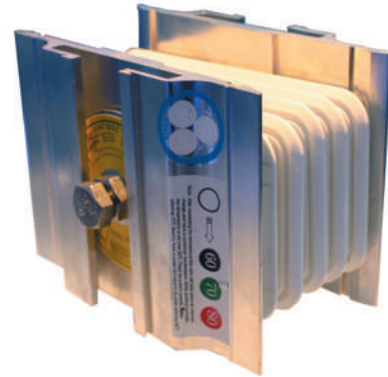

Discard the traditional design, use a single bolt clamping, making assembly fast and reliable. Its speed of assembling is 1 time faster than that of conventional joint.

Using dual-head torque bolt to ensure the pressure required for connection; Matched with a specially-crafted disk spring, to ensure the sustained pressure between connection contact surfaces.

Equipped with temperature indicator module, to remind maintenance for too high temperature rising or system fault.

Connecting busbar section is above 1.2 times than that of busbar trunking, meanwhile, contact surface is double sided lapping, effectively reducing contact resistance.

可靠的绝缘材料

Reliable Insulating Material

XL 母线槽的绝缘材料采用优质的聚酯薄膜，双层包裹，相与相之间多达六层，确保绝缘的可靠性。

该材料绝缘耐热等级为B级，单层耐压可达10000V以上，是国际IEC协会推荐使用的专业电气绝缘材料，无任何毒性，在高温状态下也不会产生有损于生物健康的物质。

The insulating materials produced by excellent used for XL Busbar are polyester films double wrapped, up to six layers between phase, ensuring the reliability of insulation.

The insulation and heat-resisting class of this material is B-class, withstand voltage of single layer is up to over 10000V. Toxic-free, no substance harmful to biological health produced under high temperature, so it is also a professional electrical insulation material recommended by IEC International Association.



【产品特点】 Product features

安全可靠的分接单元

Safe & Reliable Tapping Units

双金属插脚结构，表面镀银处理， 确保持久的接触压力和较低的接触电阻。

配备了安全连锁机构，插接箱未安装到位时，无法合闸，能够有效避免插接箱带负荷插拔。

防错相设计，确保插接箱插拔无误。

插接箱的所有带电部件均进行了有效的电气隔离，插接箱安装时，其地线先于相线与母线接通，插接箱拆卸时，地线最后断开。



Structure of bi-metal pins, silver plated, ensuring lasting contact pressure and low contact resistance. Equipped with safe interlocking mechanism, plug-in box can not be switched on/off when it is not in place, effectively avoiding on-load plugging.

Phase-dislocation proof design, ensuring correct

pluggingAn effective electrical isolation is processed to all live parts of plug-in box, when installing Plug-in box, its grounding line will be connected before phase line, while for disassembling, grounding wire will be last disconnected.

自动化铆接生产线

Automated Riveting Production Line

XL 系列母线槽系统引进德国BOLLHOFF公司专有的自冲铆接技术进行装配，使得母线槽的整体强度得到大幅度提升，同时具有优良的密封效果和电气连续性，外形整洁美观。

公司现有两条自动化程度较高的装配流水线，大大提高了装配效率和装配质量。

XL Busbar system is assembled with self-piercing riveting technology owned by German BOLLHOFF company, greatly enhancing busway overall strength. At the same time, clean and tidy in appearance, it enjoys excellent sealing effect and electrical continuity.

The company now has two assembly lines with higher automation degree, greatly increasing the assembly efficiency and quality.



【技术参数】 Technical data

动力母线槽(铜导体)

型 号		XL-C-(40A~200A)	XL-C-250A	XL-C-400A
电气参数				
额定绝缘电压 U_i	VAC	690;1000	690;1000	690;1000
过电压保护污染等级		III/3	III/3	III/3
额定工作电压 U_e	VAC	400~690	400~690	400~690
频 率	Hz	50~60	50~60	50~60
额定电流	A	40,80,100,160,200	250	300,400
电 阻	$R'20M\Omega/m$	0.66	0.3	0.14
电 抗	$X'20M\Omega/m$	0.19	0.2	0.13
阻 抗	$Z'20M\Omega/m$	0.69	0.36	0.19
短时耐受电流	I_{cw}	3.7	8	29
额定峰值电流	I_{pk}	12.5	52.5	94.5
导体材料		Cu	Cu	Cu
最大固定间距	m	3.2	3.2	3.2
均衡载荷	Kg/m	300	300	300
集中载荷	Kg/m	90	90	90
外形尺寸	mm	128 × 90	128 × 90	128 × 95
执行标准	IEC439、GB7251.6			
环境温度 min/max° c	-5/+40			
防护等级				
母线系统	IP65			
插接箱单元	IP54			
安装方式	水平安装、垂直安装、安装在一侧			
尺 寸	见参数表			
母线槽系统	铝合金外壳(氧化)、喷塑			
直线段单元	导体镀锡或镀银			
插 接 箱	钢制外壳			

备注:1、母线槽表面颜色可以根据现场和用户的要求进行设定。2、导体表面处理方式根据用户的要求选定。

【技术参数】 Technical data
动力母线槽(铝导体)

型 号		XL-A(40A~125A)	XL-A-160A	XL-A-200A	XL-A-250A	XL-A-400A
电气参数						
额定绝缘电压 U_i	VAC	690	690	690	690	690
过电压保护 污染等级		III/3	III/3	III/3	III/3	III/3
额定工作电压 U_e	VAC	400~690	400~690	400~690	400~690	400~690
频 率	Hz	50~60	50~60	50~60	50~60	50~60
额定电流	A	40,63,80,100,125	160	200	250	400
电 阻	$R'20M\Omega/m$	3.0	3.0	0.66	0.3	0.14
电 抗	$X'20M\Omega/m$	1.8	1.8	0.19	0.2	0.13
阻 抗	$Z'20M\Omega/m$	3.5	3.5	0.69	0.36	0.19
短时耐受电流	I_{cw}	3.7	3.7	3.7	8	
额定峰值电流	I_{pk}	12.5	12.5	12.5	52.5	
导体材料		AL	AL	AL	AL	AL
最大固定间距	m	3.2	3.2	3.2	3.2	3.2
均衡载荷	Kg/m	150	150	150	150	150
集中载荷	Kg/m	70	70	70	70	70
外形尺寸	mm	128×90	128×90	128×90	128×95	128×100
执行标准	IEC439、GB7251.6					
环境温度 min/max $^{\circ}C$	-5/+40					
防护等级						
母线系统	IP65					
插接箱单元	IP54					
安装方式	水平安装、垂直安装、安装在一侧					
尺 寸	见参数表					
母线槽系统	铝合金外壳(氧化)、喷塑					
直线段单元	导体镀锡或镀银					
插 接 箱	钢制外壳					

备注:1、母线槽表面颜色可以根据现场和用户的要求进行设定。2、导体表面处理方式根据用户的要求选定。

【产品编号】Product Numbering

XL 系列母线槽 XL Series Busway

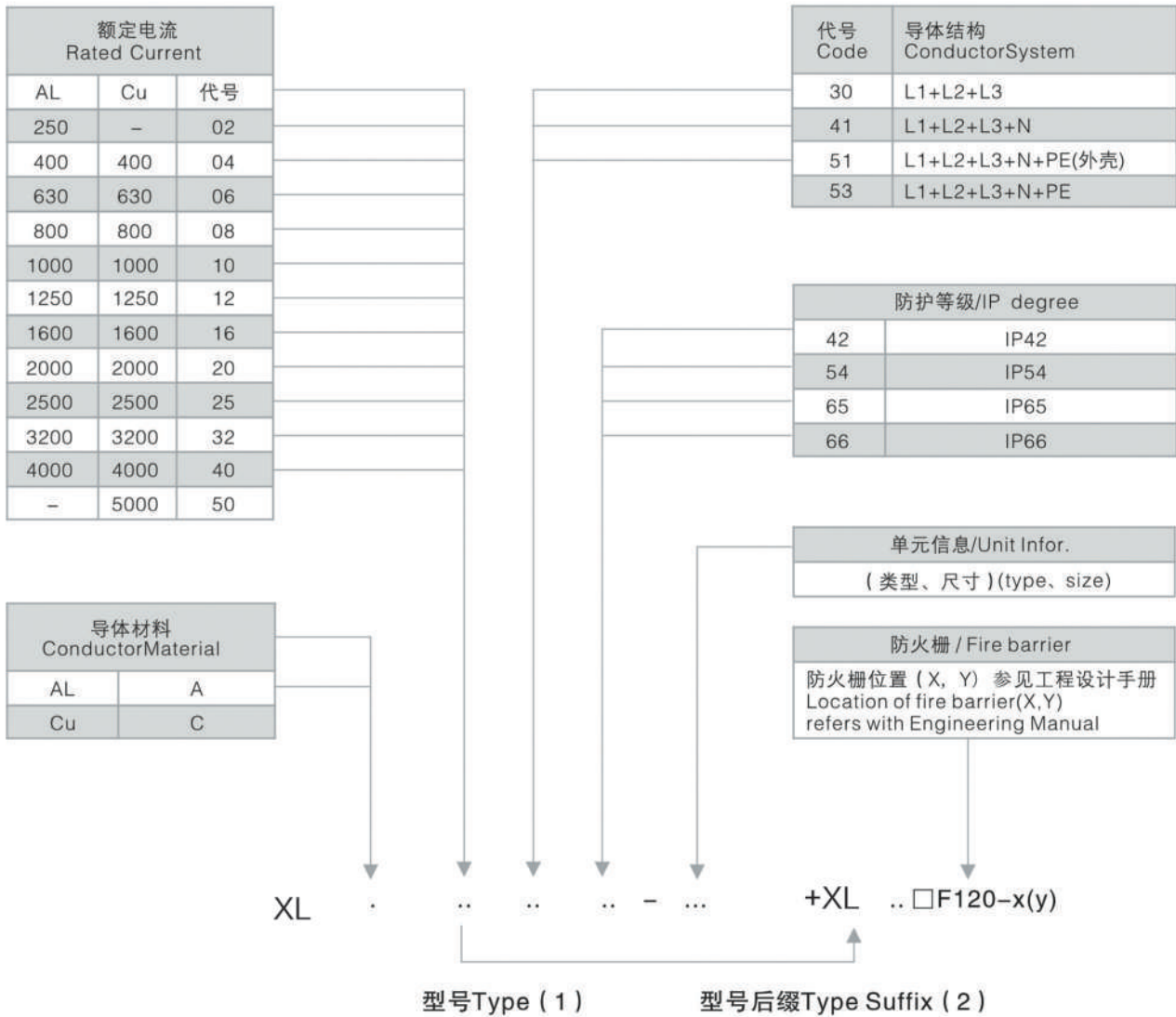

举例说明：XL C045365-3表示：

型号为XL、电流等级为400A、五线制（有单独PE排）、防护等级为IP65、长度=3米的铜母线直线段。

For Instance : XLC045365-3 indicates

XL series, rated current 400A, five wire(with internal PE), IP65, straight length L=3m copper busway

【产品编号】Product Numbering

XL 系列插接箱 Series Plug-in Box

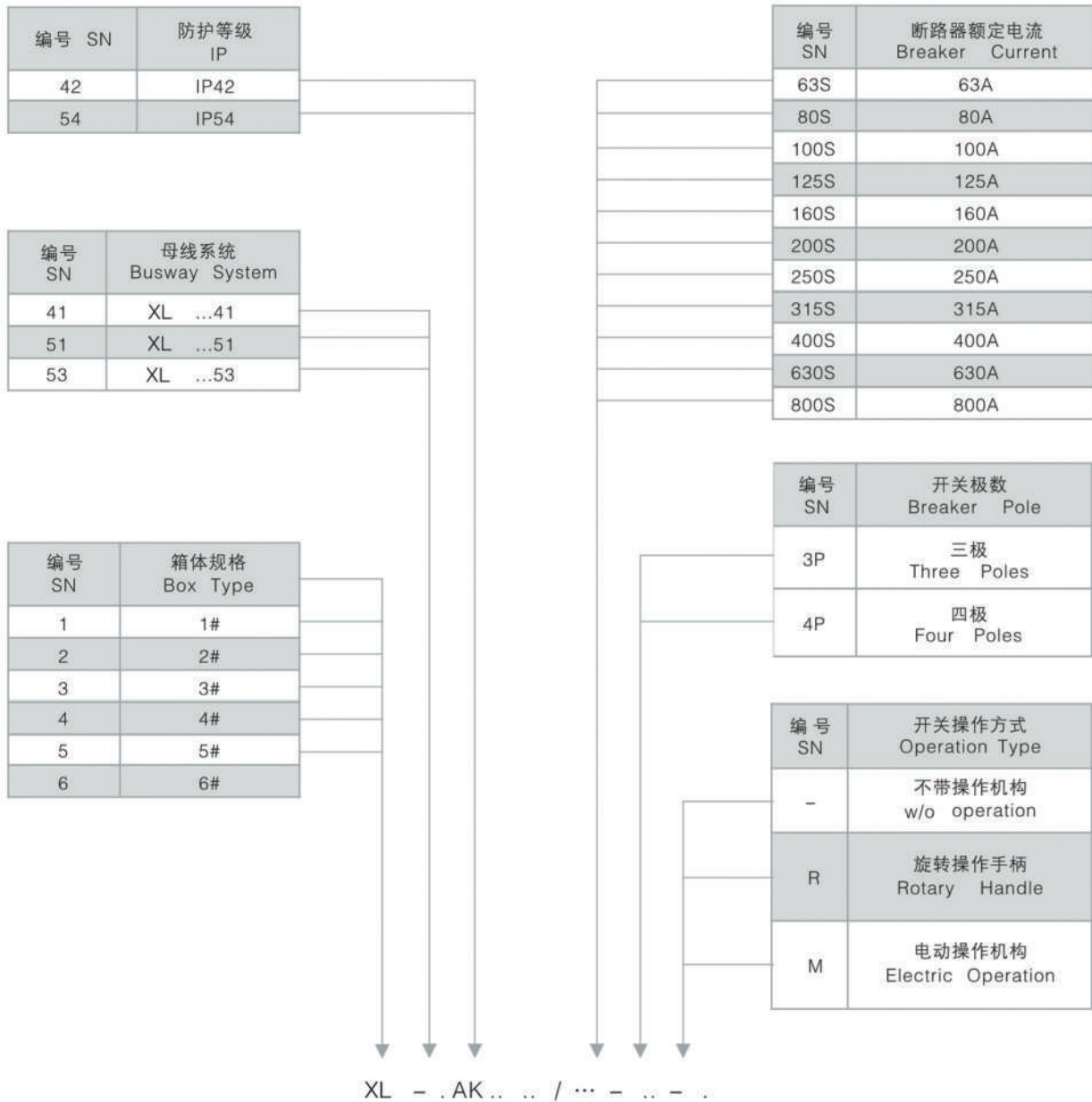

举例： XL-3AK5354/200S-3P-R 表示箱体规格为3#、母线系统为53、防护等级为IP54的插接箱，采用断路器保护并带有旋转操作手柄，断路器为3极、额定电流为200A。

For instance: XL-3AK5354/200S-3P-R indicates Plug-in box type 3#, system 53, IP54, c/w breaker with rotary handle, 3 poles and rated current 200A.

【功能单元】Fittings

直线段母线槽 Straight length

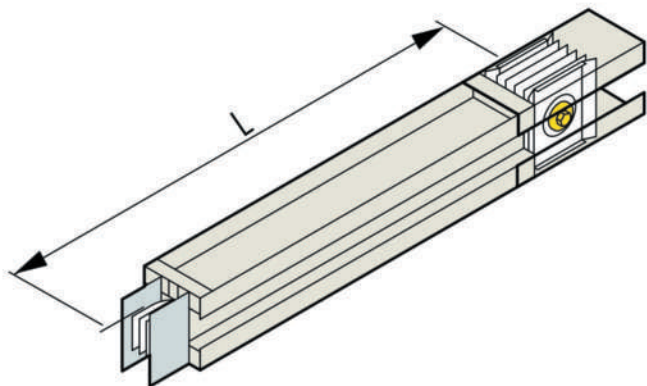

标准长度	Standard length
XL C-04-50	L=1、2、3m
可选长度	Optional length
XL C-04-50	L=0.39~4.5m

标准长度	Standard length
XL A-02~40	L=1、2、3m
可选长度	Optional length
XL A-02~40	L=0.39~4.5m

带插口直线段 Straight length with outlet

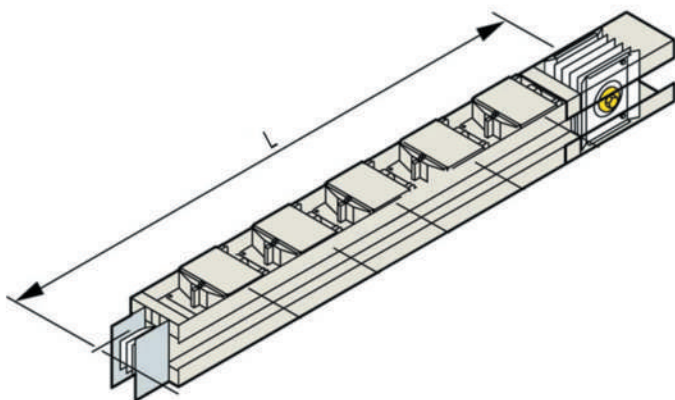

标准长度	Standard length
XL C-04-50	L=1、2、3m
可选长度	Optional length
XL C-04-50	L=0.7~4.5m

标准长度	Standard length
XL A-02~40	L=1、2、3m
可选长度	Optional length
XL A-02~40	L=0.7~4.5m

【功能单元】Fittings

水平弯母线槽 Flatwise Elbow

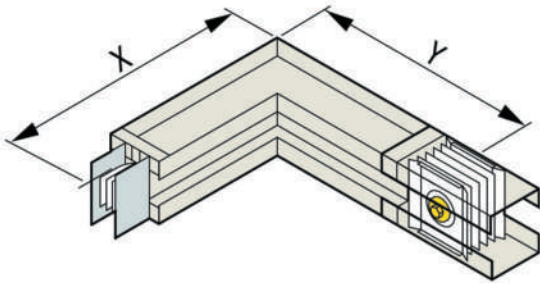

标准长度	Standard length
XL C-04-50	X/Y =0.4m
标准长度	Standard length
XL A-02~40	X/Y =0.4m

垂直弯母线槽 Edgewise Elbow

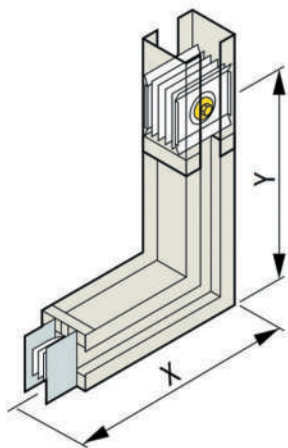

标准长度	Standard length
XL C-04-12	X =0.40m Y=0.40m
XL C-16~25	X =0.55m Y=0.55m
XL C-32~50	X =0.80m Y=0.80m

标准长度	Standard length
XL A-02~16	X =0.50m Y=0.50m
XL A-20~40	X =0.85m Y=0.85m

Z型垂直弯母线槽 Z flatwise Elbow

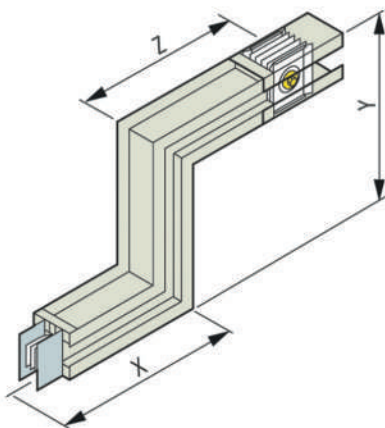

标准长度	Standard length
XL C-04-12	X =0.40m Y =0.45~1.0m Z=0.40m
XL C-16~25	X =0.55m Y =0.70~1.2m Z=0.55m
XL C-32~50	X =0.80m Y =1.20~1.7m Z=0.80m

标准长度	Standard length
XL A-02~16	X =0.50m Y =0.65~1.2m Z=0.50m
XL A-20~40	X =0.85m Y =1.30~1.8m Z=0.85m

【功能单元】Fittings

Z型水平弯头 Z edgewise Elbow

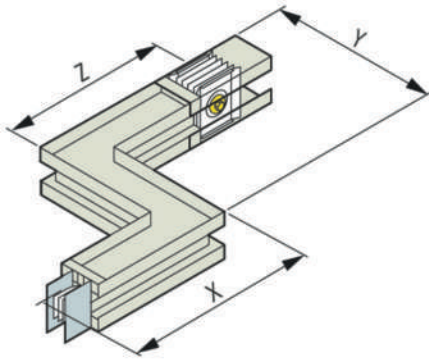

标准长度	Standard length
XL C-04-50	X =0.40m Y =0.4~1.0m Z=0.40m
标准长度	Standard length
XL A -02~40	X =0.40m Y =0.4~1.0m Z=0.40m

水平垂直弯头 Combination Elbow

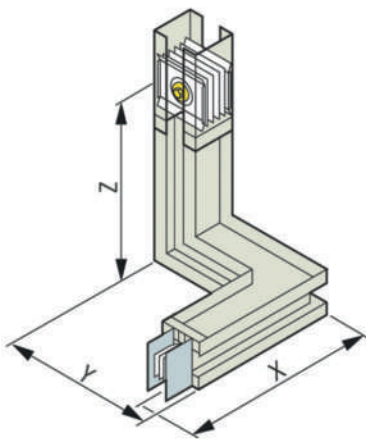

标准长度	Standard length
XL C-04-12	X =0.4m Y =0.40m Z=0.40m
XL C-16~25	X =0.4m Y =0.55m Z=0.55m
XL C-32~50	X =0.4m Y =0.80m Z=0.80m

标准长度	Standard length
XL A -02~16	X =0.4m Y =0.50m Z=0.50m
XL A -20~40	X =0.4m Y =0.85m Z=0.85m

T型垂直弯头 Tee edgewise

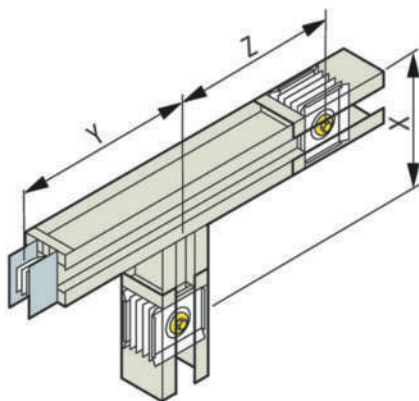

标准长度	Standard length
XL C-04-12	X =0.40m Y =0.35m Z=0.35m
XL C-16~25	X =0.55m Y =0.40m Z=0.40m
XL C-32~50	X =0.80m Y =0.55m Z=0.55m

标准长度	Standard length
XL A -04~16	X =0.50m Y =0.40m Z=0.40m
XL A -20~40	X =0.85m Y =0.55m Z=0.55m

【功能单元】Fittings

与低压柜连接单元 Switchgear connection unit

我们提供专门的始端进线单元和完整的连接单元实现 XL 母线槽系统与配电柜的连接，连接时根据用户低压柜的具体出线方案进行调整设计，即可顶端出线，也可底端出现，电流最高可达5000A。通常使用连接铜排转接，公司负责提供原材料及现场的指导安装，安装时保持现场最短路径。进线单元的始端母线配置有连接法兰，与设备紧密配合，从而保证了较高的防护等级。

We provide specialized end feeders and complete connection units for the connection of XL busway system and switchgear panel. The connection unit is designed according to the outgoing scheme of switchgear panel, from the top or from the bottom, current up to 5000A. Currently use copper bar for connection, we provide the material and site installation guide, and make the length shortest. A flange is set for tightly fit and ensure the IP rating.

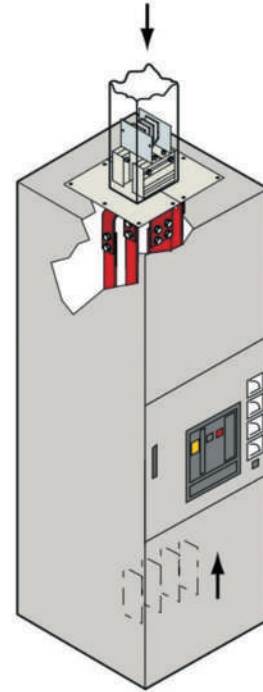

与变压器连接单元 Transformer connection unit

XL 母线槽单元可与不同规格型号的变压器连接，最大电流可以达到5000A，工厂提供完整的软连接单元，外形美观、安全可靠，能有效避免由于变压器运行时微震造成紧固件的松动，从而影响到整个配电系统的运行。我们可以按照变压器的具体出线方式进行调整设计，同时提供单独的柜顶箱单元，以防止带电部件的裸露，提高了系统的防护等级和安全性能。

XL busway system can match with transformers of different specification, current up to 5000A, the factory can provide flexible copper bar for the connection, which can avoid loosening of fastener during the operation. The connection unit is designed according to the way of transformer's outgoing. A box is also provided to prevent the live parts being exposed so as to improve the protection and safety.

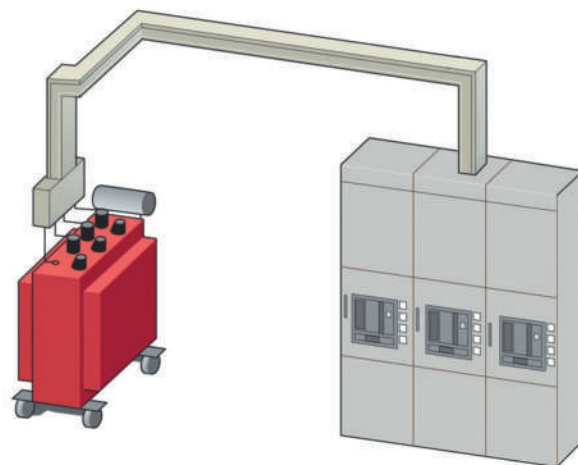

【功能单元】Fittings

插接箱单元 PLUG-IN BOX

XL 插接箱单元是将电能从母线槽系统分接到负载上并且作为开断分支电流的装置。该单元结构紧凑、外形美观、性能可靠、规格齐全，可满足不同用户的需求。

XL Plug-in box is designed to apply electrical power directly from the busway system. It has compact structure, fine appearance, reliable performance and a full line of specification, can meet the requirements of all customers.

技术参数:

额定电流:

16~630A为单插口分接

800~1000A为双插口分接或螺栓分接

1000~1600A为螺栓分接

额定电压: AC380V~690V

额定频率: 50Hz~60Hz

Technical Data:

Rated current:

16~630A adopts single outlet

800~1000A adopts double outlets or bolted-on connection

1000~1600A adopts bolted-on connection

Rated voltage: AC380V~690V

Frequency: 50Hz~60Hz

内部配置:

XL 在设计时充分考虑了用户的要求, 提供了内部装断路器或者熔断器进行保护的多种选择。

断路器的型号规格可由用户自行选择, 包括保护开关的附件, 比如操作手柄、分励脱扣、热磁脱扣、漏电保护模块等, 公司将按照用户的要求提供标准配置。

XL Fully considered customer's requirements, it offers the option of circuit-breaker and fuse.

Circuit-breaker has optional specification, including accessories of breakers such as rotary handles, shunt release, thermal magnetic release and leakage-current protection module, we will provide standard configuration according to customer's requirement.

外形尺寸/Dimension (L×W×H)

非标尺寸和大电流等级的插接箱请与厂商联系

For the plug-in box with non-standard dimension and large ratings, please contact the manufacturer

电流等级 (A)	插接箱外形尺寸 / Dimension		
	长度 L (mm)	宽度 W (mm)	高度 H (mm)
100	360	250	250
160	400	250	250
250	500	270	270
400	650	310	310
630	850	340	340
800~1000	1200	420	350

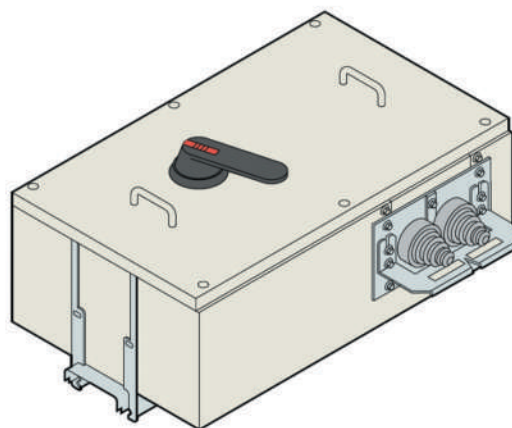

注:

1. 上表尺寸是根据常规3p/4p断路器尺寸确定的。
2. 所有数据均为标准的产品, 特殊要求可以订制。

Note:

1. Table above is based on the size of common circuit-breaker 3p/4p.
2. All the data indicates standard product, also available for customized.

【安 装】Installation

XL 母线槽水平安装时

XL busway horizontal installation



馈电式母线槽Feeder busway



插接式母线槽Feeder busway with outlet

XL 母线槽系统安装连接

Fittings XL busway system installation

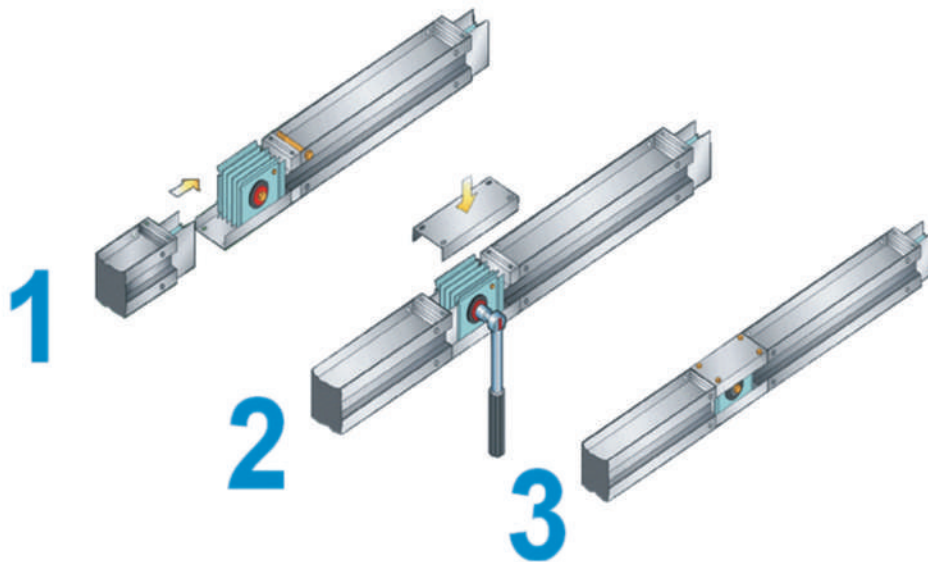

XL 母线槽系统安装连接

XL busway system installation

【安 装】Installation

XL 母线槽垂直安装时

XL vertical mounting

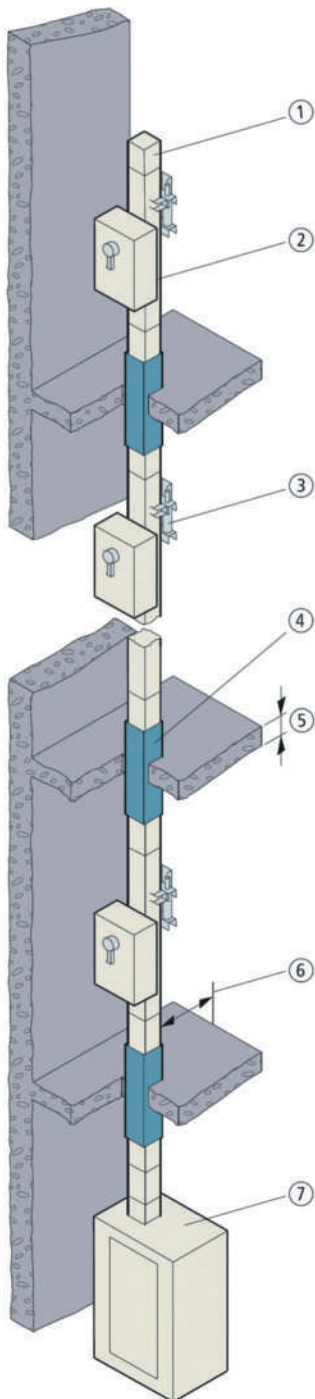

母线槽系统垂直安装时，对于插接箱的安装方式有着明确的规定，一般采用底部出线的方式，特殊情况下，可以根据用户的要求非标设计。

当XL 母线槽垂直安装时，需要采用特殊的安装附件（弹簧支架），弹簧支架的数量和规格与母线槽的电流等级和楼层高度高度有关，同时还要考虑插接箱所带来的额外重量。

弹簧支架的作用主要是为了承载母线槽自身的重量以及运行时产生的线性膨胀所带来的影响。

For vertical installation, Plug-in box has a well-define mounting type, the outgoing of the cables is from the bottom of Plug-in box, non-standard design can be provided if there are some special requirements .

Spring hangers are used for the vertical mounting, the specification and quantity of spring hangers are based on the rated current of busway and the height of building, the weight of Plug-in box should also take into account.

Spring hangers are used for bearing the weight of busway and eliminating the effect of line expansion during operation.

- 1、终端 / terminal unit
 - 2、插接箱单元 / Plug-in box
 - 3、弹簧支架 / spring hanger
 - 4、防火栅 / fire barrier
 - 5、天花板厚度 / thickness of ceiling
 - 6、安装支架距离墙面一般应大于10 cm
clearance between fixing brackets and wall should be more than 10 cm
 - 7、配电柜 / switchgear panel
- 注：插接箱数量依据用户需求
Note: Quantity of TOU depends on customer' s requirements

【安装】Installation

安装所需的最小距离

Minimum clearance for installation

水平安装 Horizontal mounting

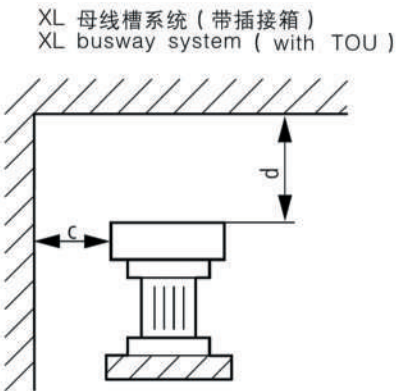
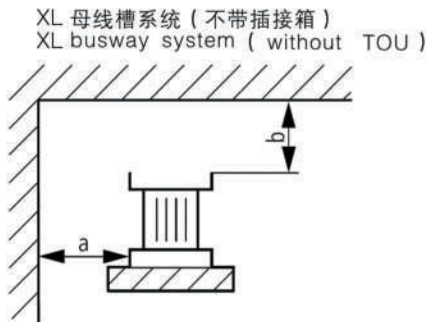

垂直安装 Vertical mounting

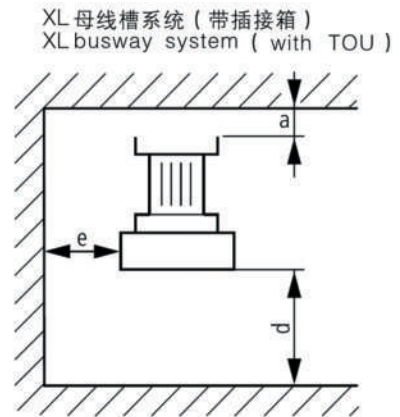
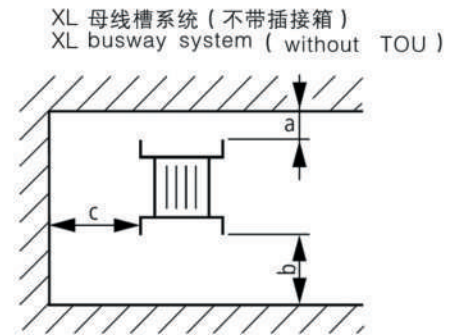

电流等级 Current	a/mm	b/mm	c/mm	d/mm
250	100	100	100	500
400	100	100	100	500
630	100	100	100	500
800	100	100	100	500
1000	100	100	100	500
1250	100	100	100	500
1600	100	100	100	500
2000	100	100	100	500
2500	100	100	100	500
3200	100	100	100	500
4000	100	100	100	500
5000	100	100	100	500

电流等级 Current	a/mm	b/mm	c/mm	d/mm	e/mm
250	100	100	100	500	100
400	100	100	100	500	100
630	100	100	100	500	100
800	100	100	100	500	100
1000	100	100	100	500	100
1250	100	100	100	500	100
1600	100	100	100	500	100
2000	100	100	100	500	100
2500	100	100	100	500	100
3200	100	100	100	500	100
4000	100	100	100	500	100
5000	100	100	100	500	100

【安装】Installation

吊顶吊装 Overhead support

单排
Single bar

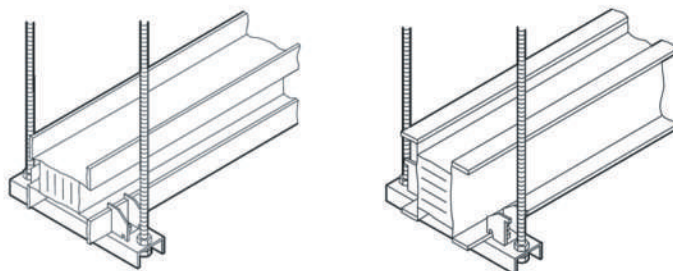

双排
Double bar

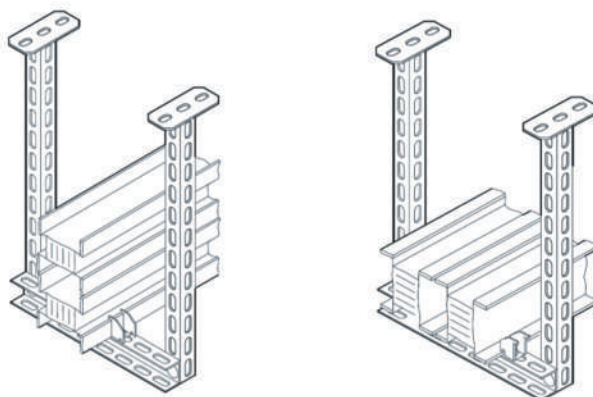

支架支撑 Fixing bracket

单排
Single bar

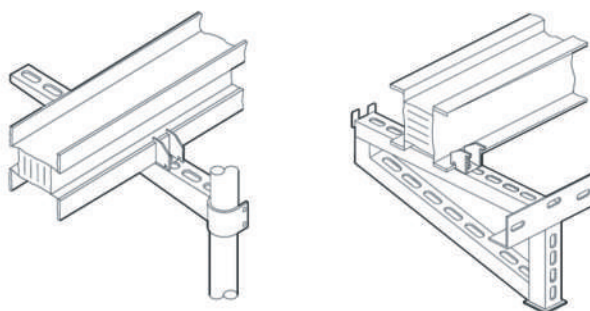

双排
Double bar

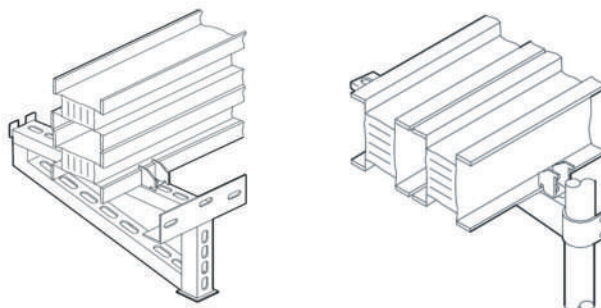

【系统概述】 System overview

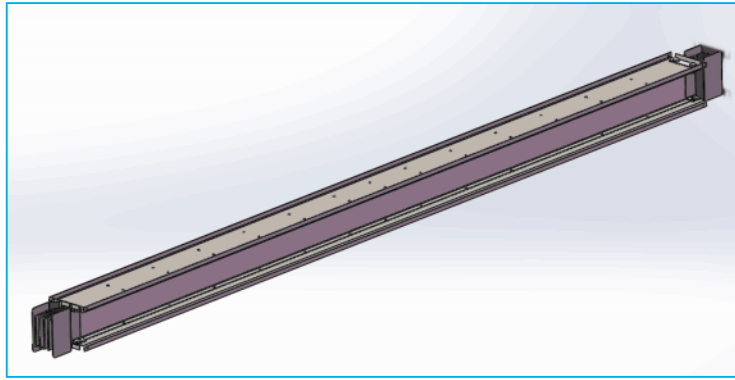

耐火型母线槽由涂有防火涂料的外壳,包缠耐火陶瓷化复合带的母线和由耐火绝缘材料制成的支架组成。支架上开有多个长腰孔槽,由水平压板及垂直压板将耐火母线固定于支架上。在母线槽的一端有母线槽连接始端箱,在母线槽内有母线分接盒。耐火型母线槽具有优良的绝缘性能,既可在正常环境中连续使用,又可在失火环境中连续使用1小时到3小时以上,可适用于高层建筑及重要设施中,如安装有发电机的重要厂房及办公场所等,代替耐火电缆起输配电作用,其输电电流等级大,维修方便可靠,使用年限远比电缆长久,综合使用成本远低于耐火电缆。

There a fireproof coating covers on the busbar, wrap the ceramic composite tape and made by fireproof isolation materials. Some elliptical holes in the support part, the vertical and horizontal plates fix the fireproof busbar on the support parts. There is the connection beginning box at its one side, the tap box inside the busbar. It has a good isolation capability, can be used continuous both in normal and fire environment last 1 to 3 hours, which can used in high building and important establishment, such as the plant with generator or office place, what transmit powers instead of fireproof cables. Its current outgoing is high and easy of maintaining, use lifespan is longer than cable, and the complete cost is much lower than fireproof cable.

结构特点 structure feature

与一般的传统耐火母线相比,我公司的耐火母线槽具有以下明显优势:

We have following advantages definitely than the traditional busbar:

1、采用合理的“三明治”相线紧密叠压结构设计,母线槽外形紧凑,体积小,母线系统具有阻抗低、电压降低、动热稳定性好的优点。

Closed and pressed Sandwiches' design, compact appearance and small volume. There are some advantages like low impedance, decrease voltage and good dynamic thermal stability.

2、外壳采用冷成型薄钢型材混合组成。大电流等级的耐火母线我司采用,独创的双层壳体双层耐火涂料防护的优化结构,双保护结构可以有效阻止高温气体或明火直接进入母线槽内部。母线槽外壳表面为镀锌加喷防火涂料(遇火时,涂料能迅速以几何速度在母线表面膨胀,形成致密的碳化隔热层,密闭母线外壳所有缝隙,防止高温直接进入母线内部)。

The enclosure formed by cold shaped and thin steel. Out busbar with high current adopts an optimization structure with unique double housing and fireproof painting, the double protection can prevent the high temperature gas or fire from going inside the busbar. The housing surface covers the galvanization and fireproof painting. (the painting can expand in geometric speed immediately and form a dense carbonization insulation layer, close all the gaps and prevent the high temperature from going inside it.)

3、接头采用专用耐火型绝缘组件,连接可靠方便。

Special fireproof isolation parts of connection end, reliable and convenience connection.

4. 相排之间的绝缘采用母线国内领先的陶瓷化复合带进行绝缘,其性能可靠,环保,无卤无毒,比由岩棉包覆的传统母线,散热好,温升低。生产方便。

The isolation between phase bars are advanced ceramic composite tape, reliable capability and environment protect. No halogen no poison. Better heating, lower temperature rise and more convenient production than traditional busbar.

【技术参数】 Technical parameters

基本参数 Basic data

执行标准 Standard	IEC/EN60439.1和2, GB7251.1和2 IEC/EN60439.1&2, GB7251.1&2, GA/T 537-2005
证书/Certificate	CCC
系统 System	三相四线, 三相五线 3P4W, 3P5W
环境温度 Ambient temperature	不超过+40°C, 24小时内平均不超过+35°C Less than +40°C, average less than +35°C within 24 hours.
防护等级 IP Rating	IP41、IP55、IP65
安装方式 Mounting Position	水平安装/垂直安装 Horizontal and vertical install
导体材料 Conductor	铜排镀锡 Tin-plating cover on the copper bar
母线颜色 Color	静电粉末喷涂, RAL7032(浅灰)(可根据客户要求) Powder painting with static-electricity, RAL7032 (depends on customer's requirements)
额定绝缘电压 U_i AC(V) Rated insulation voltage	1000
额定工作电压 U_e AC(V) Rated operation voltage	380~1000
额定频率(Hz) Rated frequency	50/60
母线电流(A) Rated current	400~5000A
插接箱电流(A) Plug-in box current	16A起, 最大可达 1600A From 16A to 1600A
电压类别/污染等级 Voltage rank/Pollution degree	III/3

短路强度 Basic data

铜导体

额定电流 A	额定短时耐受电流 ICW(KA)	额定峰值耐受电流 IPK(KA)
400	30	63
630		
800		
1000		
1250		
1600	80	176
2000		
2500		
3200		
4000	100	220
5000		

【系统概述】 System overview

全封闭环氧树脂浇注母线系统

1KV XL-R 低压母线系统 630A-6300A

Super compact resina busbar system

1KV XL-R low-voltage busbar system 630A-6300A

产品主要特性 Main features

防火

Fireproof

耐火极限时间长，性能可靠稳定，可应用于消防安全要求高的场合。

防腐

Anticorrosive

可有效防止电、化学腐蚀，能在高腐蚀性环境中长期适用。

防水

Waterproof

IP68的高防护等级可应用在户外、电缆沟等恶劣环境中使用。

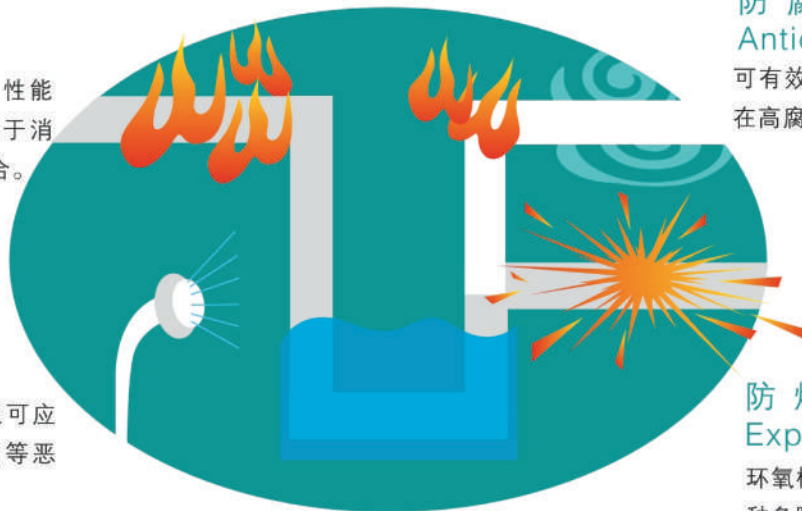

防爆

Explosive resistant

环氧树脂浇注外壳能适用于各种危险性环境。

IP68超高防护

其他优势

环氧树脂混合物配方独特
功能单元可定制
机械强度高
短路强度大
过载能力强
适用性强
安装简便
终身免维护

Other advantages

Unique epoxy-resin mixture
Tailor made functional unit element
High mechanical strength
High short-circuit strength
High over-load capability
Strong adaptability
Simple installation
Maintenance free

XL-R 环氧树脂全封闭浇注母线设计有1KV 定电流从630A-6300A，防护等级高达IP68，是低压配电领域的新一代输配电系统。XL-R 全封闭浇注母线能适用于各种恶劣与高洁净环境，被广泛应用于造船、电厂、石油化工、钢铁冶金、机械电子和大型建筑等各种场所。

XL-R super compact resina busbar from 1KV voltage system with rated current range from 630A-6300A have a degree of protection IP68, is developed as a new transmission and distribution system in low voltage installations and widely used in shipbuilding, electrical factory, petrochemical, steel metallurgy, mechanical electronic and large buildings, etc.

【产品应用】Products application



为石油精炼提供现代化的输配电系统

要求

为满足现在与未来的安全标准，石化行业的输配电在室内和室外都应要求高等级防护。

解决方案

XL-R 系统防护等级IP68实现户外输配电——连接户外变压器和室内配电屏，可提供经济式试验的标准连接单元与XL-M系统相连，实现由户外到户内的输配电转换。

成效

标准连接部件均通过型式试验确保安全性，防护等级高。安装母线槽系统之间，以及与配电屏的连接采用标准连接部件，设计简单，安装快捷，高度节约成本，属于安全、紧凑的连接方案。

为地铁隧道提供安全配电系统

要求

地铁区间基础设施排风扇和用电设备对配电系统的安全性要求较高，特别是需要提供高等级人身保护，防止人为破坏。

解决方案

XL-R 系统具备应用连贯性，对额外的措施具备持久的功能，IP68高等级防护。

成效

实现免维护；结构紧凑，节省空间；环氧树脂外壳抵抗力高；实现理想的系统和人身保护。



Modernized power transportation for oil refinery

Requirements

To meet current and future safety standards, the realization of the power supply for a petrochemical plant required high degrees of protection, both for the indoor and outdoor applications.

Solution

XL-R system with IP68 for outdoor power transportation—between outdoor transformers and internal power distribution boards Type-tested standard connection between the XL-R and XL-M systems for further power distribution inside the building with XL-R system

Result

Safety through type-tested components, connection pieces and high degree of protection Easy planning and mounting through standard connection components between the busbar trunking systems and power distribution boards Safe, compact and cost-effective solution

Safe power distribution in subway tunnel

Requirements

A safe power distribution solution was required for the smoke fans and consumers in the track section of a subway infrastructure. Important factors entailed a high personal protection and prevention of vandalism.

Solution

Consistent application of the XL-R system Functional endurance with additional measures High degree of protection IP68

Result

High availability through maintenance-free technology Minimum space requirements through compact dimensions High resistance through epoxy cast-resin enclosure Ideal personal and system protection

【系统图】 System diagram

1. 直线段
Straight trunking units
2. 进线单元
Feeder units
3. 换相单元
Junction units
4. 插接单元
Tap off units
5. 附件
Accessories
6. XL-M 耦合单元
Adapter for the XL-M
7. 膨胀节
Expansion compensation
8. 连接单元
Encapsulated joint unit

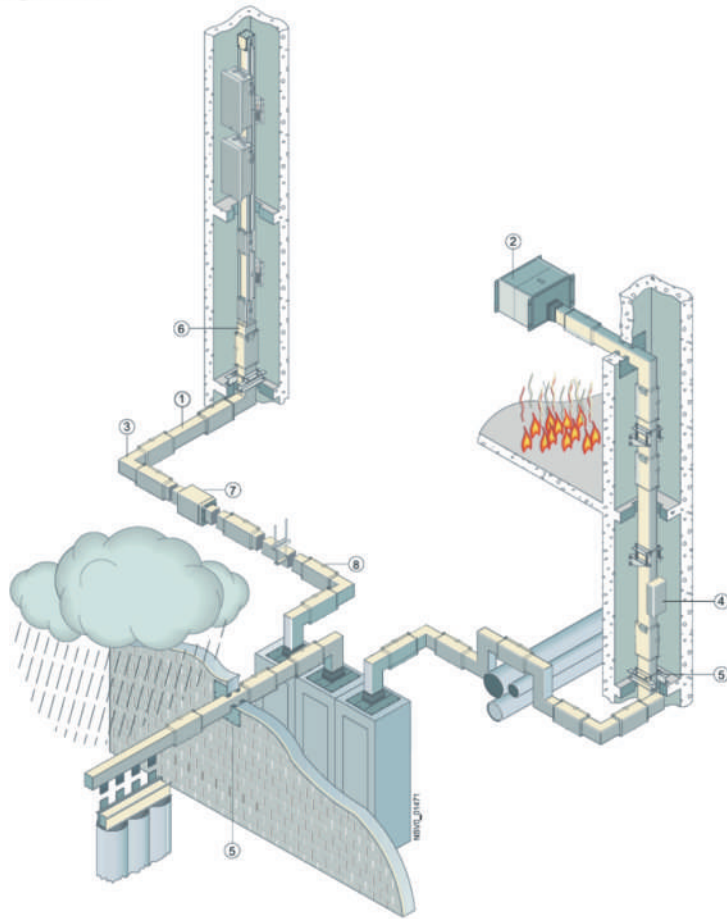

系统通用参数

General technical data for XL-R

系统通用标准	IEC/EN61439-6, GB7251.6-2015
额定绝缘电压 U_i	AC/DC1000
额定工作电压 U_e	Ac1000
频率 Hz	50...60
额定工作电流 I_e	630A-6300A
防护等级 IP	
母线部件	Ip68
连接部件/插接单元	Ip68
导体 conductor	铜排或铝排 Copper or Aluminium
外壳 enclosure	环氧树脂 Resina
安装方式 Mounting position	水平、垂直 Edgewise, flat,
颜色 color	RAL7032 (浅灰)

【系统概述】System overview

1. 直线段
Straight trunking units
2. 换相单元
Junction units
3. 进线单元
Feeder units
4. 插接单元
Tap off units
5. 附件
Accessories

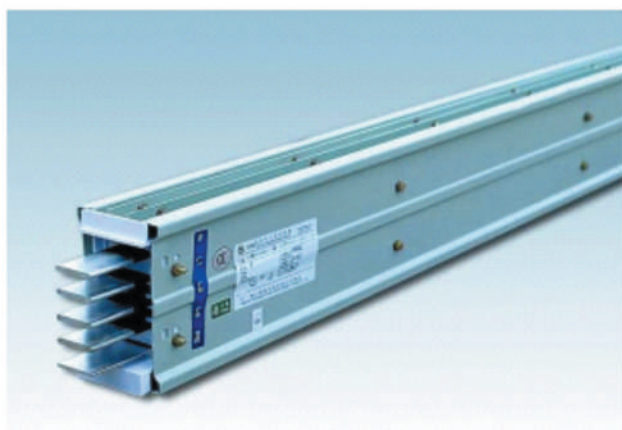
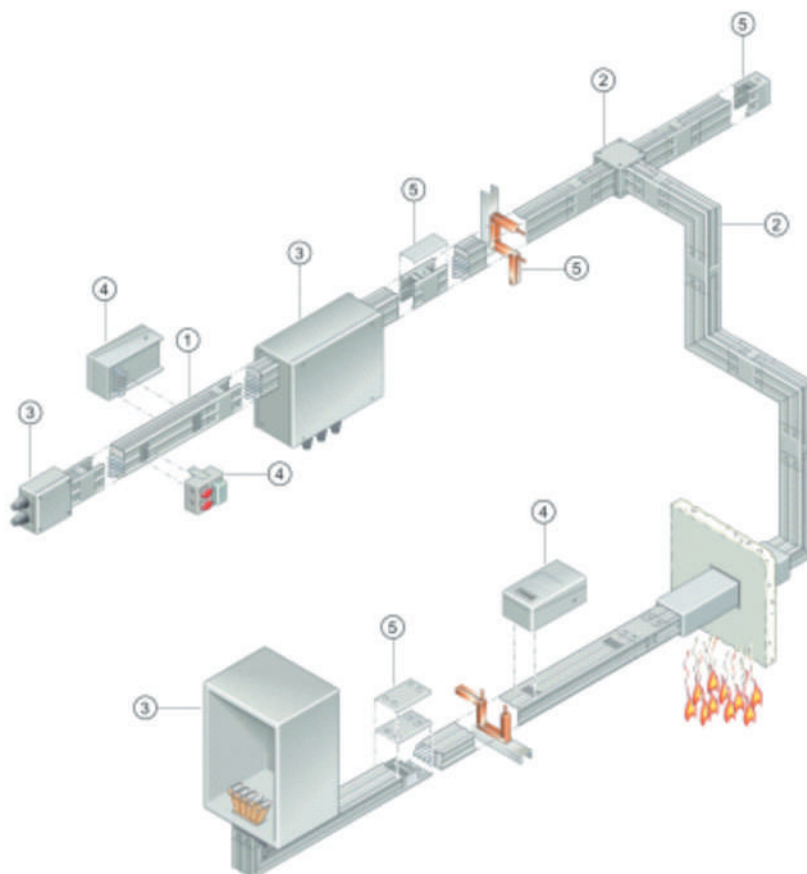

系统配置

XL-K空气附加绝缘型母线槽系统主要为负载供电，额定工作电压690V，频率50~60Hz，额定工作电流160~1250A，分接电流最大630A，防护等级可达IP54。有铜排和铝排两种配置，适用于三相四线制、三相五线制等供配电系统。

System Description

XL-K air-insulated busway mainly applies for power supply, rated operation voltage up to 690V, IP degree up to IP54 and the frequency 50~60Hz, rated current from 160A to 1250A, maximum tapping current 630A, with copper or aluminium conductor, suitable for three-phase four-wire, three-phase five-wire power supply and distribution.

【技术参数】Technical parameters

基本参数 Basic data

执行标准 Standard	IEC/EN61439-6, GB7251.6-2015
证书 / Certificate	CCC
系统 System	三相四线, 三相五线 3P4W, 3P5W
环境温度 Ambient temperature	不超过+40°C, 24小时内平均不超过+35°C Does not exceed +40°C, does not exceed +35°C within 24 hours
防护等级 IP Rating	IP54
安装方式 Mounting Position	水平安装 / 垂直安装 Horizontal / Vertical
导体材料 Conductor	铜排镀锡, 铝排镀铜锡 Copper bar with tin plated, copper plated and tinned
母线颜色 Color	静电粉末喷涂, RAL7032 (浅灰) Electrostatic powder coating, RAL7032 (light gray)
插口配置 Outlet design	标准3米长直线段可以在正反面设置1-6个插接口 Standard 3000mm length can have 1-6 outlets on both sides
额定绝缘电压 U_i AC (V) Rated insulation voltage	690
额定工作电压 U_e AC (V) Rated operation voltage	380~690
额定频率 f (Hz) Rated frequency	50/60
母线电流 (A) Rated current	160~1250
插接箱电流 (A) Plug-in box current	16A起, 最大可达630A From 16A to 630A
电压类别/污染等级 Voltage rank/Pollution degree	III / 3

短路强度 Short-circuit ratings

铜导体 Copper conductor

额定电流 (A)	额定短时耐受电流 I_{CW} (KA)	额定峰值耐受电流 I_{PK} (KA)
250	20	40
400		
630	30	63
800		
1000		
1250		
1600	50	105
2000		
2500	80	176
3200		
4000		
5000	100	220

铝导体 Aluminum conductor

额定电流 (A)	额定短时耐受电流 I_{CW} (KA)	额定峰值耐受电流 I_{PK} (KA)
160	20	40
250		
400		
630	30	63
800		
1000		
1250	50	105
1600		
2000	80	176
2500		
3200		
4000		

【系统概述】 System overview

1. 干线单元(3、4、5线制)
trunk unit (3/4/5 wires)
2. 馈电单元(进线单元、出线单元)
feedback unit (incoming and outgoing unit)
3. 附件
Accessories
4. 插接单元(3级、5级)
plug unit (3 and 5 poles)
5. 终端法兰
(terminal flange)

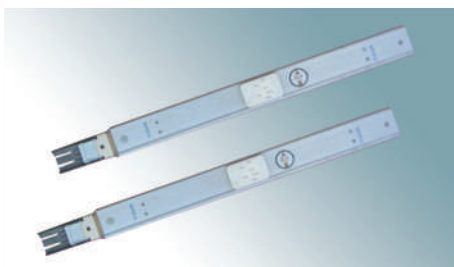
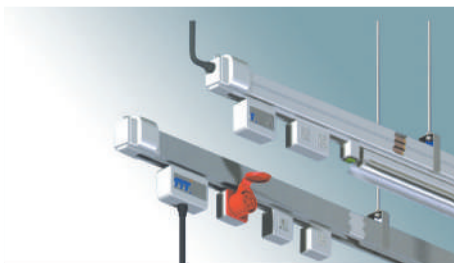
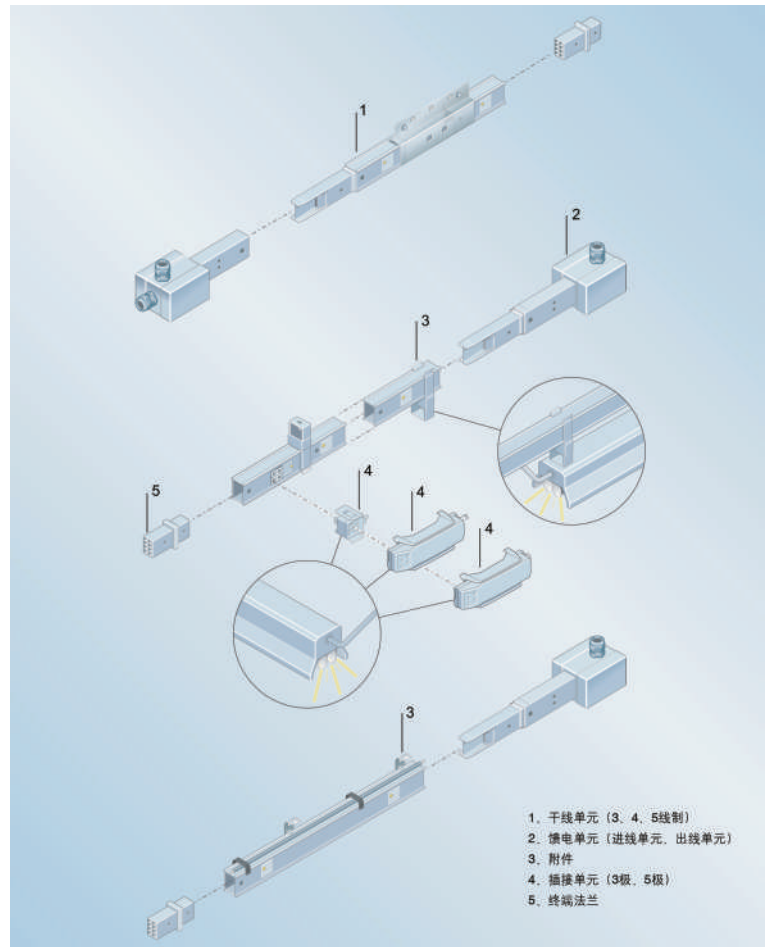

系统概述 systems summary

XL-ZM 微动力照明母线槽系统为空气绝缘型,适用于小型动力负载和照明供电。额定工作电压为 380~1000V,频率 50~60Hz,额定工作电流 40~250A,分接电流为 10A~160A,防护等级最高可达 IP55。导体为铜排,适用于三相四线制、三相五线制等供电系统。

XL-ZM system is air isolation, which is suit for low dynamic load and lighting. Its rated work voltage is 380~1000V, frequency is 50~60Hz, rated work current is 40~250A, branch current is 10A~160A, and the IP degree can achieve IP55. The conductor is copper bar and applies to the supply system of 3 phases and 4 wires and 3 phases and 5 wires.

结构特点 structure feature

母线槽外壳采用钢制外壳或铝合金外壳,装配简单快捷,外形美观。各电流等级母线槽采用同一规格外壳,连接处采用标准连接端子,通用性好。利用绝缘件支承并隔开绝缘导线,用电安全可靠。提供各种现场安装方法,用户可根据需要灵活使用。

Its outside is steel or aluminum, simple and fast for assembling and beautiful appearance. The busbar during each adapt the shell with the same specification, the normal terminal connected and good generally. The isolation parts support and isolate the wire, safety and reliable for operation. We provide all kinds of install ways, and you can choose by yourself depends on your requirements.

【 技术参数 】 Technical parameters

基本参数 Basic date

执行标准/Standard	IEC/EN 61439-6, GB7251.6-2015
证书/Certificate	CCC
系统 System	三相四线, 三相五线 3P4W, 3P5W
环境温度 Ambient temperature	不超过+40℃, 24小时内平均不超过+35℃ Less than +40℃, average less than +35℃ within 24 hours.
防护等级 IP Rating	IP41、IP55
安装方式 Mounting Position	水平安装/垂直安装 Horizontal and vertical install
导体材料 Conductor	铜排镀锡 Tin-plating cover on the copper bar
母线颜色 Color	静电粉末喷涂, RAL7032(浅灰) Powder painting with static-electricity, RAL7032 (depends on customer's)
插口配置 Outlet design	标准3米长直线段可以在正反面设置1-8插接口 Set 1-8 plug point in both sides in normal 3 meters straight line.
额定绝缘电压 Ui AC(V) Rated insulation voltage	1000
额定工作电压 Ue AC(V) Rated operation voltage	380~1000
额定频率(Hz) Rated frequency	50/60
母线电流(A) Raged current	50~250
插接箱电流(A) Plug-in box current	16A起, 最大可达 160A From 16A to 160A
电压类别/污染等级 Voltage rank/Pollution degree	III/3
额定短时耐受电流 ICW(KA)	10
额定峰值耐受电流 IPK(KA)	17

安全警告

Warning

- 1、母线槽系统属于低压成套电气设备，请严格按照低压电气操作规范执行
 - 2、母线槽在安装前中后，都应防止水、盐、混凝土等其它杂物的侵入和腐蚀
 - 3、在没有完全安装结束前，户外设备不具备防风雨的能力，应采取防雨及防暴晒措施
 - 4、禁止坐、站立或在设备上行走
- 1、Busway system belongs to low voltage whole-set electrical equipment, please handle it per the instruction of electrical operation specification.
 - 2、Before, during or after installation, busway should be protected from the ingress or corrosion of water, salt, concrete or other foreign matter.
 - 3、Before the complete installation, care should be taken to prevent rain and storm for outdoor device
 - 4、Sit, stand or walk on the busway is strictly forbidden.

装卸

Loading

- 1、全过程防止潮湿、雨淋、化学物质的侵入
 - 2、小心装卸，避免母线槽扭曲、碰撞和重压
 - 3、装卸时，必须在中心起吊，不可在地上或槽体之间拖拉
 - 4、装卸工具建议使用叉车较为方便
- 1、Avoid moisture, rain or chemical substances.
 - 2、While loading, avoid stress on the busway or collision.
 - 3、When lifting the busway, make sure the busway weight is distributed and balanced ; Never drag busway on the ground.
 - 4、Use a forklift to handle the busway.

储存

storage

- 1、防止灰尘和液体侵入，并远离通道
 - 2、不要储存在室外，避免阳光暴晒
 - 3、母线槽应堆放在等高的木块上并且隔开，最多不超过5层
 - 4、安装前不要将包装全部拆除
- 1、Avoid dust and liquid, away from the aisle.
 - 2、Never put it outdoor, avoid direct sun exposure.
 - 3、Busway should stack on the wood block and keep apart; no more than five pieces should be stack on the top of each other.
 - 4、Do not remove the whole packing material before installation.

使用

Usage

- 1、检查母线槽系统的相序，应该正确一致
 - 2、确认母线槽系统不受液体、固体的侵入
 - 3、保证母线槽的支架安装稳固、螺栓连接可靠
 - 4、测量母线槽系统的绝缘电阻，不得低于0.4MΩ
 - 5、母线槽开始送电时，不得带负载
 - 6、检查总的负载电流不得超过主母线电流或设计电流
- 1、Check the phase sequence of busway.
 - 2、Make sure the busway is protected from dust and liquid.
 - 3、Ensure the steady of fixing brackets and reliable connection of bolts.
 - 4、While energizing the busway, all the tapping devices should be in off position.
 - 5、All load currents should no more than rated current of busway.

维护

Maintenance

- 1、必须切断母线槽电源，才能进行维护保养工作
 - 2、使用三个月后应停电检查螺栓紧固情况，每年全面检查
 - 3、出现异常情况请立即断电检查，确定情况后再作处理
 - 4、必须消除影响母线槽正常运行的不利因素，如滴水、粉尘、热源等
- 1、Power should be cut off before maintaining the busway system.
 - 2、Check the tightness of bolt after first use of 3 months, and then check it annually.
 - 3、Cut off power if any abnormal condition occurs, and then find out the reasons and take measures.
 - 4、Keep the system away from the adverse factors, such as water, powder, and heat source.



江苏宏鹏电气科技有限公司

JIANGSU HONGPENG ELECTRIC TECHNOLOGY CO.,LTD.

地 址：扬中市新坝镇港东南路66号

电 话：13376190001 18912110008

传 真：0511-88416898

邮 箱：744234123@qq.com

邮 编：212211

本公司保留对样本所涉及内容的修改权和最终解释权.如有改动,恕不另行通知.
This company reserves the right to revise and to explain finally for this catalog.subject to change without prior notice.